



# AQUAX

WATER SOLUTIONS & BEYOND  
[www.aquax-solutions.com](http://www.aquax-solutions.com)



## Features

- 10 to 2,000 gallons
- 150/233/350 PSI pressure rating
- Built-in pressure gauge
- Stainless steel water connection NPT / Flange
- Tanks come complete with lifting lugs to allow easy on-site handling
- AquaX tanks come complete with a pressure switch connection on top of each tank for onward connection to pump control systems
- Replaceable Heavy Duty membrane design



## Stainless Steel Pressure Tanks

**AquaX Series** tanks are ideally suited for applications where high-volumes and/or high-pressure ratings are required. These applications may include pressure booster systems, hot/cold water circulation systems as well as water hammer arresting in high-rise and multistory buildings such as hotels, hospitals, or business centers.

**AquaX Series** tank volumes range from 10 gallon up to 2,000 gallon making AquaX Series one of the most comprehensive pressure tank lines globally. The interchangeable membrane design allows the end user to replace the membrane as required, and the built-in pressure gauge allows for easy and efficient pressure monitoring.

**AquaX Series** tanks are designed to the EN13831:2007 technical standard and produced in accordance with the Pressure Equipment Directive 2014/68/EU. The tanks are inspected at several stages during production to ensure premium quality and represent the best value for the investment. Given regular pre-charge maintenance, we recommend checking tank pre-charge every 9-12 months, **AquaX Series** tanks will serve your needs for years to come.

### Interchangeable Membrane Design

1. Membrane hanger
2. Stainless steel tank shell
3. Pre-charged air
4. Built-in pressure gauge
5. Water chamber
6. Air valve
7. High grade membrane
8. High precision welded seam
9. Bolted flange

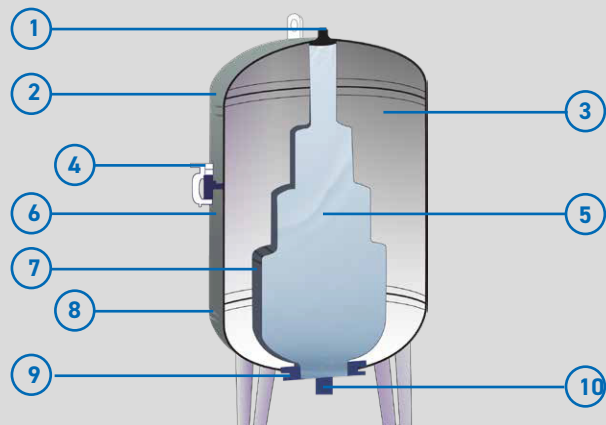

10. Stainless steel water connection